

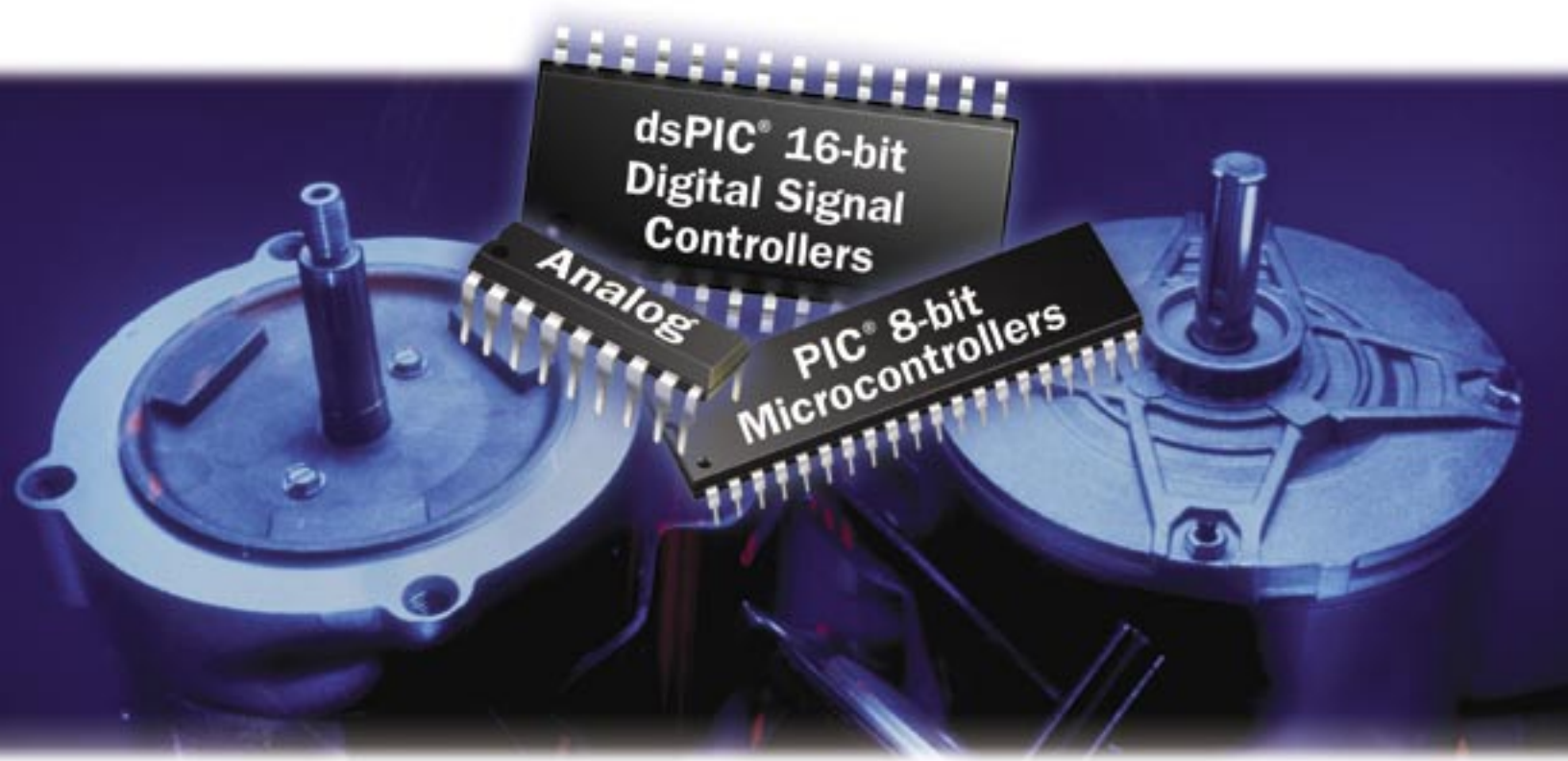

## Motor Control Design Solutions



# Motor Control Design Solutions

Microchip Technology offers a broad product portfolio that provides a complete system solution for your stepper motor, brushed DC motor, AC induction motor, variable speed brushless DC motor, and switched reluctance motor applications. With our sophisticated development systems and technical documentation, Microchip makes it easy for designers of all experience levels to complete a high performance electronic motor control design quickly and cost effectively. Only Microchip provides everything a motor control design engineer needs: low-risk product development, lower total system cost, faster time to market, outstanding technical support and dependable delivery and quality.

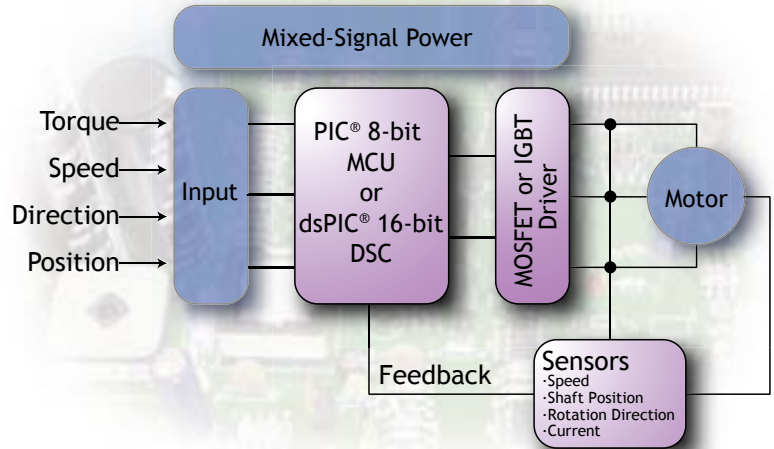

## Microchip's Recommended Solutions for Motor Control Designs\*

Motor Type	PIC® 8-bit Microcontrollers	dsPIC® 16-bit Digital Signal Controllers**	MOSFET Drivers	Fan Managers	Analog Peripherals	Development Tools
Stepper	PIC16F684 PIC16F716 PIC16F7X7	dsPIC30F5015	TC141X TC442X TC446X	--	-MCP606, MCP616 Op Amps -TC913X Auto-Zeroed Op Amps -TC7652 Chopper Op Amp -TC74, TC1047A, TC6501 Temperature Sensors -TC102X, TC654X Voltage Comparators	-Motor Control Graphical User Interface -dsPIC™ Motor Control Development System
Brushed DC	PIC16F684 PIC16F716	dsPIC30F2010	TC141X TC442X	TC642 TC647B TC670	-MCP606, MCP616 Op Amps -TC913X Auto-Zeroed Op Amps -TC7652 Chopper Op Amp -TC74, TC1047A, TC6501 Temperature Sensors -TC102X, TC654X Voltage Comparators	-Motor Control Graphical User Interface -TC642EV Fan Controller Evaluation Kit -dsPIC Motor Control Development System
AC Induction	PIC16F7X7 PIC18FXX31	dsPIC30F2010 dsPIC30F3011 dsPIC30F5015 dsPIC30F6010	--	--	-MCP606, MCP616 Op Amps -TC913X Auto-Zeroed Op Amps -TC7652 Chopper Op Amp -TC74, TC1047A, TC6501 Temperature Sensors -TC102X, TC654X Voltage Comparators	-Motor Control Graphical User Interface -PICDEM™ MC Development Board -dsPIC Motor Control Development System
Variable Speed Brushless DC	PIC18FXX31	dsPIC30F2010 dsPIC30F3011 dsPIC30F5015 dsPIC30F6010	TC141X TC442X	TC642 TC647B TC670	-MCP606, MCP616 Op Amps -TC913X Auto-Zeroed Op Amps -TC7652 Chopper Op Amp -TC74, TC1047A, TC6501 Temperature Sensors -TC102X, TC654X Voltage Comparators	-Motor Control Graphical User Interface -PICDEM MC Development Board -TC642EV Fan Controller Evaluation Kit -dsPIC Motor Control Development System
Switched Reluctance	PIC18FXX31	dsPIC30F2010 dsPIC30F3011 dsPIC30F5015 dsPIC30F6010	TC141X TC442X	--	-MCP606, MCP616 Op Amps -TC913X Auto-Zeroed Op Amps -TC7652 Chopper Op Amp -TC74, TC1047A, TC6501 Temperature Sensors -TC102X, TC654X Voltage Comparators	-Motor Control Graphical User Interface -dsPIC Motor Control Development System

\*This table represents a sampling of device solutions recommended for motor control design. Microchip's broad portfolio of 8-bit microcontrollers, 16-bit digital signal controllers, analog and interface products, serial EEPROMs and related development systems contains hundreds of products that could potentially be used for motor control design, depending upon the application requirements.

\*\*Please check with your local Microchip distributor, sales representative or sales office for availability and the latest product information.

## Advanced On-chip Peripherals

Microchip offers dedicated families of PIC 8-bit microcontrollers (MCUs) and dsPIC 16-bit digital signal controllers (DSCs) that provide on-chip peripherals to design high-performance precision motor control systems that are more energy efficient, quieter in operation, have greater range and an extended life:

- High-speed 10-bit analog-to-digital converter (up to 500 ksps operation)
- High-endurance data EEPROM (up to 4K bytes)
- Specialized motor control PWM, up to eight channels and four duty cycle generators with flexible modes of operation
- Up to eight Enhanced Capture, Compare, PWM (ECCP) modules
- Quadrature Encoder (Interface or Input Captures)

## Mixed-Signal Power Devices

For advanced high voltage, power management technology, turn to an industry leader -- International Rectifier (IR). IR's iMOTION™ product portfolio for motor control designs includes insulated gate bipolar transistors (IGBTs), high voltage IC drivers, advanced power modules integrating IGBTs with 3-phase IC drivers, and switch mode power supply controllers (SMPSs). The latest integrated inverter modules, in a sleek and compact single in-line package (IRAM family), make IR an excellent choice for the power stage in motor control. For more information, go to [www.irf.com](http://www.irf.com).



## Complete Technical Resources for Motor Control Design

Microchip makes it easy to add electronic motor control functionality to your embedded design. For access to Microchip's complete motor control design resources, visit the Motor Control Design Center at [www.microchip.com/motor](http://www.microchip.com/motor). Whether you are a motor control expert or a beginner, this dedicated site provides you everything you need to complete your motor control design, including:

- Design Flow Charts. Microchip has taken the difficulty out of the motor control design process with this online resource. Starting with the motor control type, users walk through all of the required steps and questions in order to create a high-performance motor control design.
- Applications by Motor Type. This online table captures numerous end applications and their typical motor types for the industrial, automotive, consumer and appliance market segments.
- Technical Documentation. Microchip offers a variety of motor control-related application notes (see partial list to the right), reference designs and other technical documentation to help speed design time. This technical library provides both theory and operation considerations for a variety of motor types.

## Application Notes

### Stepper Motor

- AN822 Stepper Motor Microstepping with PIC18C452
- AN906 Stepper Motor Control Using the PIC16F684
- AN907 Stepper Motor Fundamentals

### Brushed DC Motor

- AN532 Servo Control of a DC Brush Motor
- AN696 PIC18CXXX/PIC16CXXX DC Servomotor
- AN718 Brush-DC Servomotor Implementation Using PIC17C756A
- AN893 Low-cost Bidirectional Brushed DC Motor Control Using the PIC16F684
- AN905 Brushed DC Motor Fundamentals

### AC Induction Motor

- AN843 Speed Control of a 3-Phase Induction Motor Using PIC18 Microcontrollers
- AN861 Smart Air Handler Using ProMPT™ and PIC18F2539
- AN887 AC Induction Motor Fundamentals
- AN889 VF Control of 3-Phase Induction Motors Using PIC16F7X7 Microcontrollers
- AN900 VF Control of 3-phase AC Induction Motors Using the PIC18F4431
- AN908 Using the dsPIC30F for Vector Control of an AC Induction Motor

### Variable Speed Brushless DC Motor

- AN857 Brushless DC Motor Control Made Easy
- AN885 Brushless DC (BLDC) Motor Fundamentals
- AN899 Brushless DC Motor Control Using PIC18FXX31
- AN901 Using the dsPIC30F for Sensorless BLDC Control

### General

- AN894 Motor Control Sensor Feedback Circuits
- AN898 Determining MOSFET Driver Needs for Motor Drive Applications

## Development Systems

Microchip offers a number of development boards and evaluation kits that demonstrate the capabilities of its motor control silicon solutions. All of the hardware and software is included to control the supported motor types. These tools make it easy to customize the software for specific motors.

### Motor Control Graphical User Interface

The MC-GUI graphical user interface allows users to configure the motor and a wide range of system parameters for a selected motor type, including speed, rotation direction, current, heatsink temperature, fault status and much more. Available at no cost, this Windows® based software program supports Microchip's motor control demonstration boards to provide a complete solution that helps reduce design time.

### PICDEM™ MC Development Board

The PICDEM MC Development Board (DM183011) gives you everything you need to evaluate Microchip's high performance PIC18FXX31 8-bit microcontrollers for motor control design. Supporting motors up to 800 Watts, the tool provides total isolation between power and control circuits, enabling users to plug in the MPLAB® In-Circuit Emulator or MPLAB In-Circuit Debugger to the board when high power is connected.

### dsPIC30F Motor Control Development System

This high performance modular system provides a method for quick prototyping and validation of various motor types. The tools give you the flexibility to select the appropriate power modules to meet your needs. Start with the dsPICDEM™ MC1 Motor Control Development Board (DM300020) and add the appropriate power module and motor for a complete system:

- dsPICDEM MC1H 3-Phase High-Voltage Power Module (DM300021)
- 3-Phase AC Induction Motor High-Voltage Motor (208/460V) (AC300021)
- dsPICDEM MC1L 3-Phase Low-Voltage Power Module (DM300022)
- 3-Phase Brushless DC Low-Voltage Motor (24V) (AC300020)

### Other Development Tools

Take advantage of Microchip's world-class development tools for PIC 8-bit microcontrollers and dsPIC 16-bit digital signal controllers, including programmers, emulators, debuggers, and additional evaluation kits. Operating under the free MPLAB Integrated Development Environment, Microchip's development systems are easy-to-use and help reduce design time.

## MOSFET Drivers for Motor Control Applications

Device	Configuration	Peak Output Current (A)	Output Resistance (Ohms)	Maximum Supply Voltage (V)
TC1410/11/12/13	Single	0.5 - 3.0	15/15 - 2.5/2.5	16
TC4421/22	Single	9	1.4 (typ)/1.7	18
TC4423/24/25	Dual	3	5/5	18
TC4426A/27A/28A	Dual	1.5	9/9	18
TC4467/68/69	Quad	1.2	15/15	18

## Fan Managers for Motor Control Applications

Device	Description	Typical Accuracy (°C)	Maximum Accuracy @ 25 °C (°C)	Maximum Temperature Range (°C)	Vcc Range (V)	Maximum Supply Current (µA)
TC642	Fan Manager	Note 1	Note 1	-40 to +85	3.0 to 5.5	1,000
TC647B	Fan Manager	Note 1	Note 1	-40 to +85	3.0 to 5.5	400
TC670	Predictive Fan Fault Detector	N/A	N/A	-40 to +85	3.0 to 5.5	150

Note 1: These devices use an external temperature sensor. Accuracy of the total solution is a function of the accuracy of the external sensor.

## PIC® 8-bit Microcontrollers for Motor Control Applications

Product	Pins	Flash KB	SRAM Bytes	EE Bytes	Timer 8/16-Bit	Comp	CCP/ECCP	Motor Control PWM	A/D 10-Bit	Quad Enc	UART	SPI™/I²C™
PIC16F684	14	5.6	128	256	2/1	2	1	—	8 ch	No	—	—
PIC16F716	18	5.6	128	—	2/1	—	1	—	4 ch (8-bit)	No	—	—
PIC16F737	28	7	368	—	2/1	2	3	—	11 ch	No	1	1
PIC16F747	40/44	7	368	—	2/1	2	3	—	14 ch	No	1	1
PIC16F767	28	14	368	—	2/1	2	3	—	11 ch	No	1	1
PIC16F777	40/44	14	368	—	2/1	2	3	—	14 ch	No	1	1
PIC18F2331	28	8	768	256	1/3	—	2	6	5 ch	Yes	1	1
PIC18F2431	28	16	768	256	1/3	—	2	6	5 ch	Yes	1	1
PIC18F4331	40/44	8	768	256	1/3	—	2	8	9 ch	Yes	1	1
PIC18F4431	40/44	16	768	256	1/3	—	2	8	9 ch	Yes	1	1

## dsPIC® 16-bit Digital Signal Controllers for Motor Control Applications\*\*

Product	Pins	Flash KB	SRAM Bytes	EE Bytes	Timer 16-Bit	Input Cap	Output Comp/Std PWM	Motor Control PWM	A/D 10-Bit 500 KSPS	Quad Enc	UART	SPI™	I²C™	CAN
dsPIC30F2010	28	12	512	1024	3	4	2	6	6 ch	Yes	1	1	1	—
dsPIC30F3010	28	24	1024	1024	5	4	2	6	6 ch	Yes	1	1	1	—
dsPIC30F3011	40/44	24	1024	1024	5	4	4	6	9 ch	Yes	2	1	1	—
dsPIC30F4011	40/44	48	2048	1024	5	4	4	6	9 ch	Yes	2	1	1	1
dsPIC30F4012	28	48	2048	1024	5	4	2	6	6 ch	Yes	1	1	1	1
dsPIC30F5015	64	66	2048	1024	5	4	4	8	16 ch	Yes	1	2	1	1
dsPIC30F6010	80	144	8192	4096	5	8	8	8	16 ch	Yes	2	2	1	2

\*\*Please check with your local Microchip distributor, sales representative or sales office for availability and the latest product information.

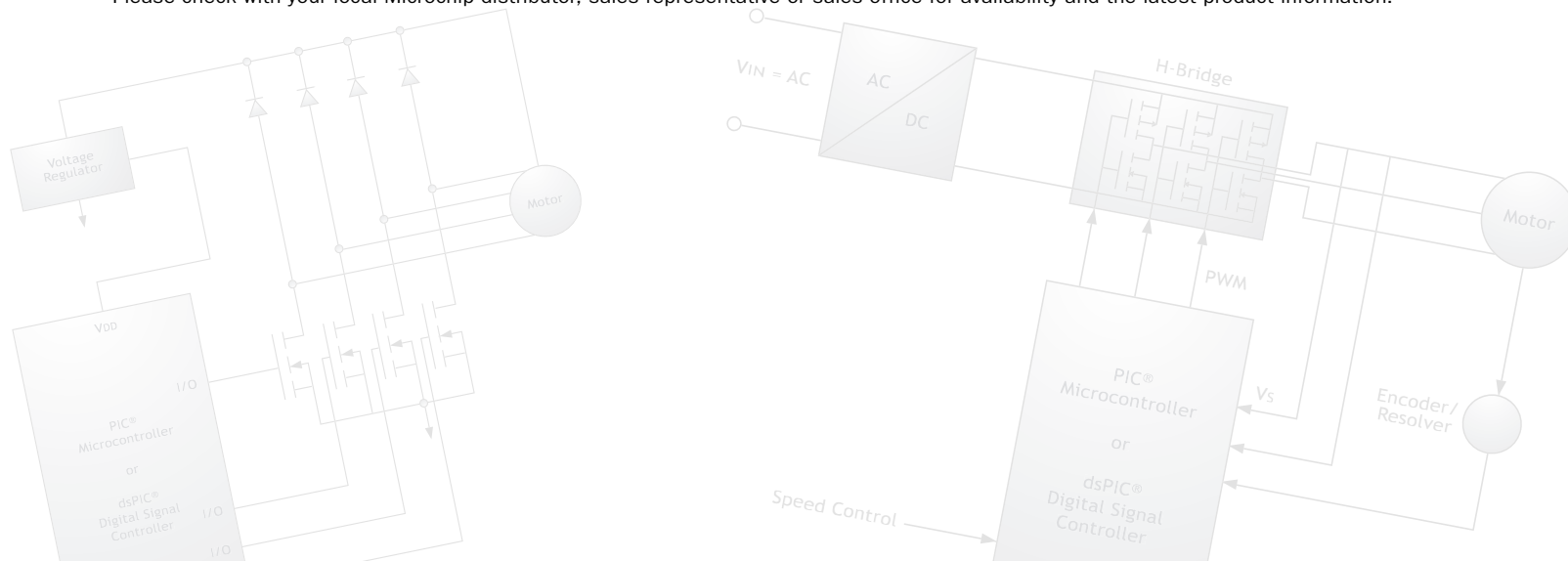

## Worldwide Sales & Service

At Microchip, we understand that it takes more than product specifications to create loyal customers. In addition to a broad product portfolio, we understand the value of a complete design solution. That's why we maintain a worldwide network of sales and support. Our technical support is unmatched with a global network of experienced field application engineers and technical support personnel ready to provide product and system assistance to help you further streamline your design, prototype, and production activities.

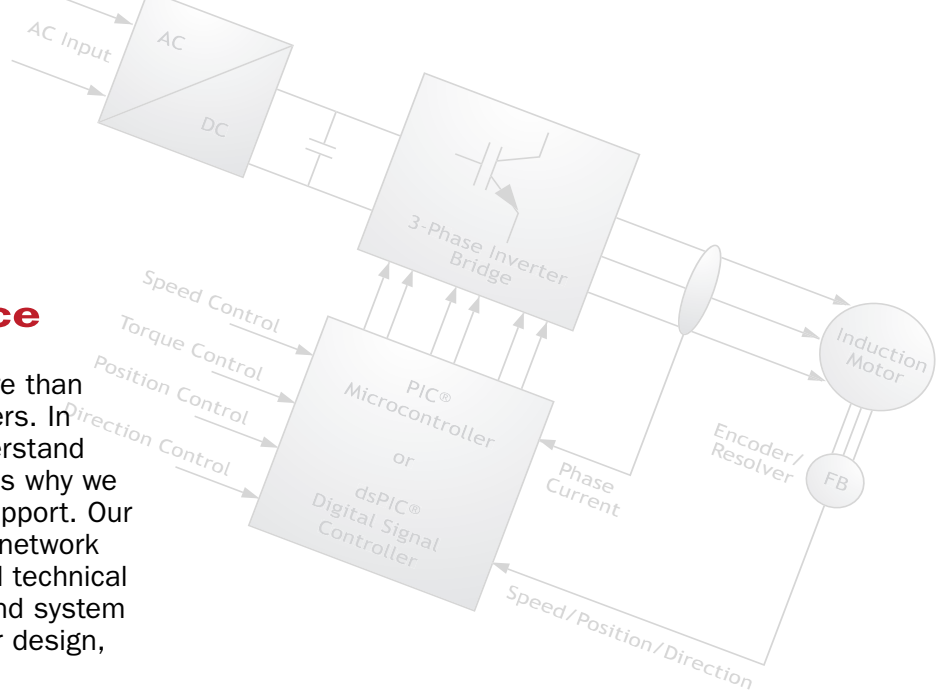

## Sales Listing

Technical Support: 480-792-7627

Web Address: [www.microchip.com](http://www.microchip.com)

### AMERICAS

Atlanta	770-640-0034
Boston	978-692-3848
Chicago	630-285-0071
Dallas	972-818-7423
Detroit	248-538-2250
Kokomo	765-864-8360
Los Angeles	949-263-1888
San Jose	650-215-1444
Toronto	905-673-0699

### ASIA/PACIFIC

Australia	61-2-9868-6733
China - Beijing	86-10-85282100
China - Chengdu	86-28-86766200
China - Fuzhou	86-591-7503506
China - Hong Kong	852-2401-1200
China - Shanghai	86-21-6275-5700
China - Shenzhen	86-755-82901380
China - Shunde	86-757-28395507
China - Qingdao	86-532-5027355
India	91-80-2290061
Japan	81-45-471-6166
Korea	82-2-554-7200
Singapore	65-6334-8870
Taiwan	886-2-2717-7175
Taiwan - Kaohsiung	886-7-536-4818

### EUROPE

Austria	43-7242-2244-399
Denmark	45-4420-9895
France	33-1-69-53-63-20
Germany	49-89-627-144-0
Italy	39-0331-742611
Netherlands	31-416-690399
United Kingdom	44-118-921-5869



**MICROCHIP**

[www.microchip.com/motor](http://www.microchip.com/motor)

2355 West Chandler Boulevard • Chandler, Arizona 85224-6199 • (480) 792-7200 • Fax (480) 792-7277

Information subject to change. The Microchip name and logo, the Microchip logo, Accuron, dsPIC, KEELOQ, MPLAB, PIC, PICmicro, PICSTART, PRO MATE and PowerSmart are registered trademarks of Microchip Technology Incorporated in the U.S.A. and other countries. AmpLab, FilterLab, microID, MXDEV, MXLAB, PICMASTER, SEEVAL, SmartShunt and The Embedded Control Solutions Company are registered trademarks of Microchip Technology Incorporated in the U.S.A. Application Maestro, dsPICDEM, dsPICDEM.net, dsPICworks, ECAN, ECONOMONITOR, FanSense, FlexROM, fuzzyLAB, In-Circuit Serial Programming, ICSP, ICEPIC, microPort, Migratable Memory, MPASM, MPLIB, MPLINK, MPSIM, PICkit, PICDEM, PICDEM.net, PICTail, PowerCal, PowerInfo, PowerMate, PowerTool, rLAB, rPIC, Select Mode, SmartSensor, SmartTel and Total Endurance are trademarks of Microchip Technology Incorporated in the U.S.A. and other countries. Serialized Quick Turn Programming (SQTP) is a service mark of Microchip Technology Incorporated in the U.S.A. All other trademarks mentioned herein are property of their respective companies. All rights reserved. Printed in the U.S.A. 01/04 ©2004 Microchip Technology Inc.

IR is a registered trademark of International Rectifier Corporation. iMOTION is a trademark of International Rectifier Corporation



\*DS00896A\*